

ENDURO BEVEL HELICAL GEARBOX

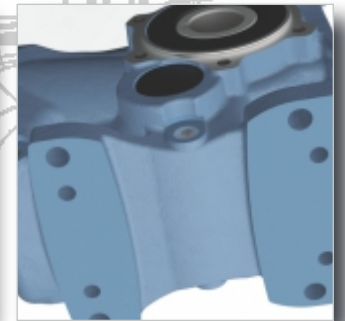

rotomotive

looks good. performs better.

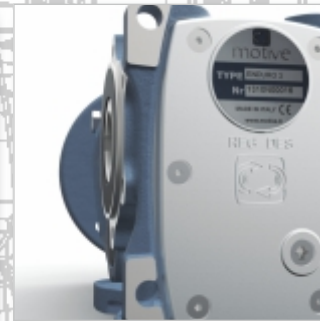
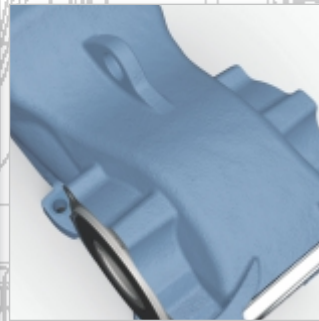
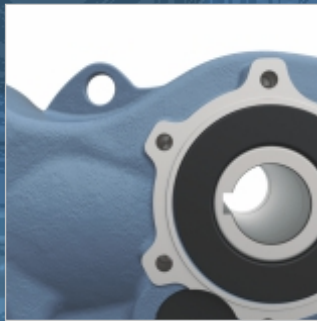
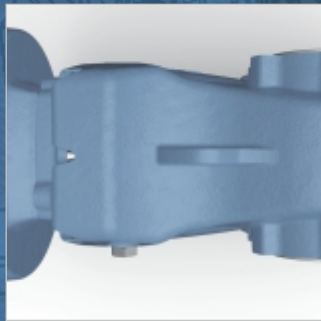
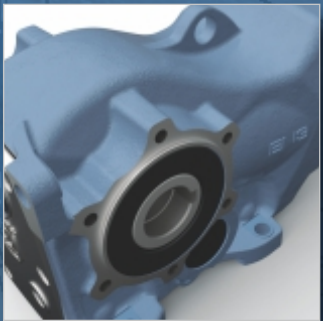



Rotomotive Powerdrives India Ltd is an Italian joint venture company operating in India since 2006. It has access to European technology and know-how from Motive srl, one of the joint venture partners and sources parts and components from Indian suppliers. We have a modern manufacturing facility in Gujarat, India. Rotomotive has the capacity to design, prototype and manufacture custom motors for various applications.

Our modern manufacturing plant has advanced machinery for automatic winding, trickle and vacuum pressure impregnation, precise balancing, conveyORIZED assembly, enclosed painting lines, automatic testing facilities with all components bar coded for traceability, consistent quality and low production time.

We also have an advanced testing facility for type testing motors and gearboxes which enables us to plot accurate speed torque curves and carry out temperature rise tests and other type tests as per IEC 60034/IS: 12615.

Our Manufacturing facility in India



Gearbox machining



Lean Assembly Line



Geared Motor Testing



Hardness Testing

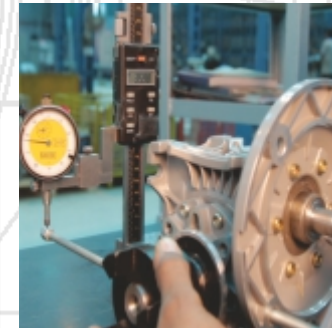

Backlash Checking



Shop Floor



Our Manufacturing facility in Italy

INDEX

Technical characteristics	pag. 2-3
Calculation of performance Parameters	pag. 4
Lubrication	pag. 5
Performance tables	pag. 6-7-8-9-10-11
List of components	pag. 12-13
Dimensions	pag. 14-15-16



A



B



C



D





ROBUST

Uniquely contoured, rigid, precise, monobloc, cast iron Body, Base and flange ensure extreme robustness.

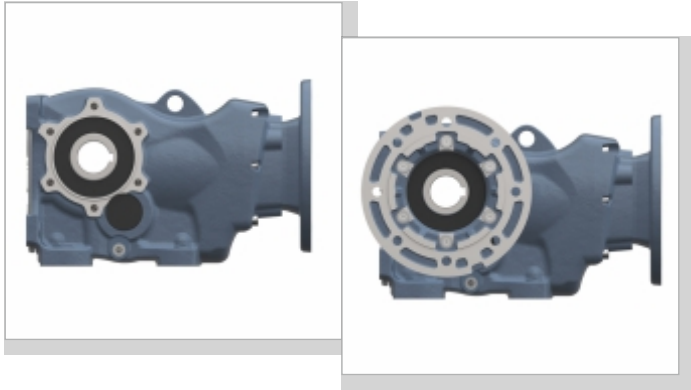
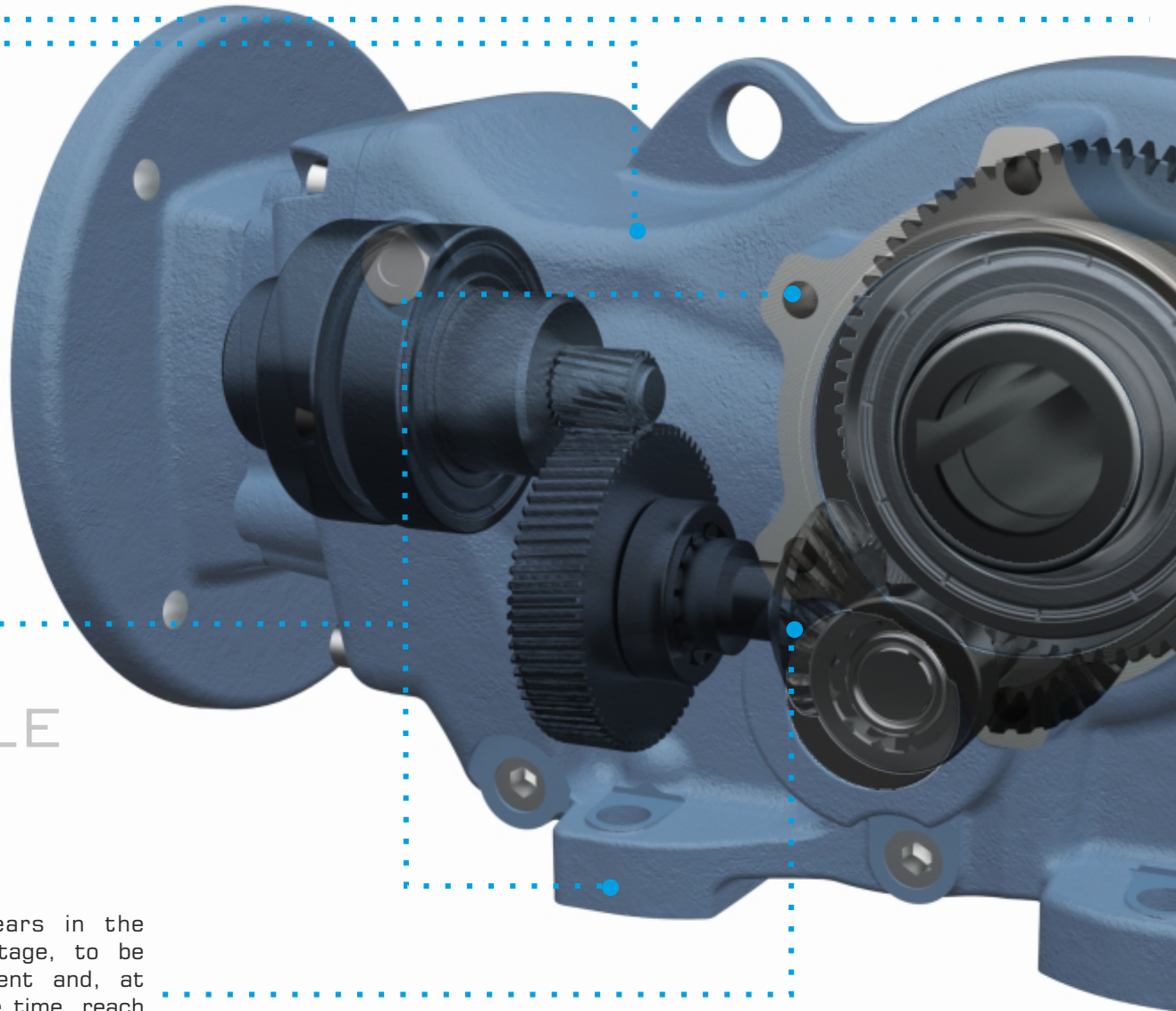

A modular design with detachable output flange and integral feet permits the easy and fast conversion between flange or foot mounting

VERSATILE



Bevel gears in the middle stage, to be more silent and, at the same time, reach a higher service factor

REGISTERED DESIGN



FLEXIBLE MOUNTING

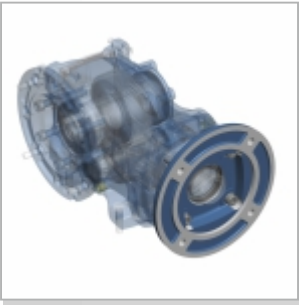

IEC flange and hollow shaft.

Choice of hollow input shaft & input flanges permits direct mounting of any IEC standard motor.



Unique construction of Enduro makes it possible to mount any size in any position. this flexibility is achieved by:

+ZZ pre-lubricated bearings on input and output shaft

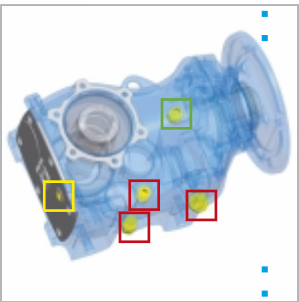

5 interchangeable plugs, including one breather plug and a level plug. Breather plug allows to reduce the internal pressure on seals and thus increases the efficiency of the seals.

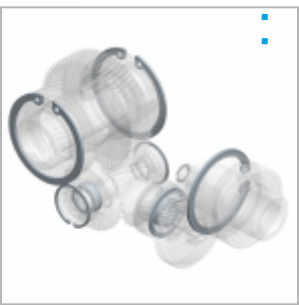

+ mechanical parts locked in their positions by snap rings. this also ensures better absorption of axial thrust and prolongs the life of bearings

ENGINEERED FOR HIGHER RELIABILITY



Use of high strength case hardened steels with case hardening to 58 ± 2 HRC reduce the wear rate. All components are profile ground to Din 3962 class 6 accuracy for low noise and high efficiency. Bevel pairs are lapped.



Shafts are made from 42CrMo4 steel and tempered to reach a hardness of 23-35 HRC, thus increasing their capacity to withstand shearing stresses.



Single stages ratios between 2 and 6, together with proper gears sizes, result mathematically in higher teeth number and size (module) of each wheel and a better fractionated load among the reduction stages. that influences both durability and torque transmission capability



Dual bearing support on the input shaft assures precise alignment of the first stage gears and reduces vibrations and consequent gear wear



Abounding bearings size, in order to withstand higher loads

Rated output torque M_{n2} [Nm]

Torque output transmissible under uniform loading and referred to the input speed n_1 and the corresponding output speed n_2 .

The output torque can be calculated with the following formula:

$$M_{n2} = \frac{P_{n1} \text{ [kW]} \cdot 9550}{n_2} \cdot \eta$$

Torque demand M_{r2} [Nm]

Torque calculated based on application requirements. It must be $\leq M_{n2}$ of the chosen ENDURO unit.

Input power P_{n1} [kW]

This is the power value of the motor applied to the input shaft and corresponding to a certain input speed n_1 , a service factor $f_s = 1$ and a duty service s_1 .

It is even possible to calculate the motor-size necessary by using the formula:

$$P_{n1} \text{ [kW]} = \frac{M_{r2} \cdot n_2}{9550 \cdot \eta}$$

Since the value calculated in this way could not really correspond to an input power actually available in the IEC standardised motors, it will be necessary to choose, among the input powers available, the one which is immediately higher, checking this in the Rotomotive catalogue of the motors.

Efficiency η [%]

An inherent factor in the selection of gear boxes is the efficiency η , defined as the ratio between the mechanical power coming out from the output shaft, and the power in the input shaft:

$$\eta = \frac{P_{n2}}{P_{n1}}$$

The efficiency in helical gearboxes is

mainly determined by the gearing and bearing friction.

The efficiency of ENDURO is 94 %.

The starting efficiency is always less than the efficiency at rated speed

Gear ratio i

It is the relationship of the input speed n_1 and the output speed n_2

$$i = \frac{n_1}{n_2}$$

In the combined, the total ratio is the result of the product of the ratio of the two single boxes.

Input speed n_1 [rpm]

It is the speed the ENDURO unit is driven at.

Output speed n_2 [rpm]

It is the rotation speed of the output shaft.

Service factor f_s

It is a numeric value describing the ENDURO unit service duty. With unavoidable approximation, it takes into consideration:

- the daily working hours **h/d**
- the load classification (see table 2), and then the moment of inertia of the driven masses.
- the number of starts per hour **s/h**
- the presence of brake motors, for which it is necessary to multiply for 1.12 the service factor value deducted by the graph 2.
- the significance of the application in terms of safety, for example lifting of parts

In the graph 2, the service factor f_{sr} required by a certain application can be attained, after having selected the proper "daily working hours" (h/d) starts per hour (s/h) and one of the a, b or c curves. the curves a, b and c are linked with the load

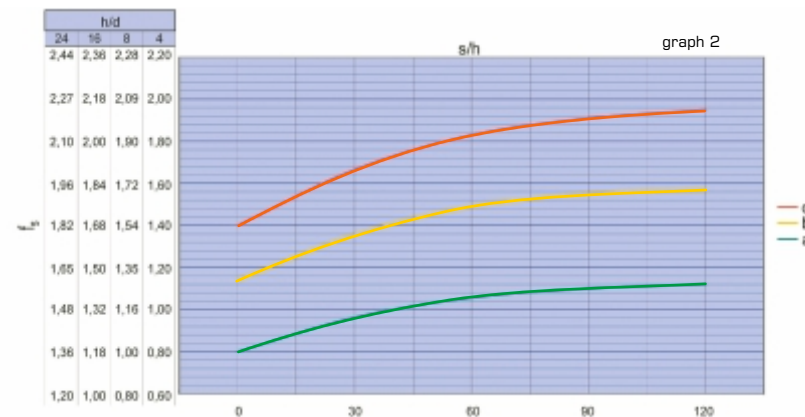

tab. 2

load classification	application
c uneven operation, heavy loads, larger masses to be accelerated	conveyors with violent jerks; compressors ad alternate pumps with 1 or more cylinders; machinery for bricks, tiles and clay; kneaders; milling machines; lifting winches with buckets; rotting furnaces; heavy fans or mining purposes; mixers for heavy materials; machine-tools; planing kinds; alternating saws; shears; tumbling barrels; vibrators; shredders; turntables
b starting with moderate loads, uneven operating conditions, medium size masses to be accelerated	belt conveyors with varied load with transfer of bridge trucks for light duty; levelling machines; shakers and mixed for liquid with variable density and viscosity; machines for the food industry (kneading troughs, mincing machines, slicing machines, etc); sifting machines for sand gravel; textile industry machines; cranes, hoists, goodstifts; fertilizer scrapers; concrete mixers; folding machines; winches; crane mechanisms
a easy starting, smooth operation, small masses be accelerated	belt conveyors for light material; centrifugal pumps; rotary gear pumps; screw feeders for light materials; lifts; bottling machines; auxiliary controls of tool machines; fans; power generators; fillers; small mixers

classification described in the table 2. If, after the selection of the right M_{r2} and n_2 in the following performance tables, you don't find a ENDURO unit whose service factor f_s is \geq of the requested one f_{sr} , you can choose a ENDURO unit in which $M_{n2} > M_{r2}$.

In fact, in order to satisfy f_{sr} , you can choose another ENDURO unit whose output torque is $\geq M_{c2}$ output torque, where:

$$M_{c2} = M_{r2} \cdot f_{sr}$$

Note: This rule is valid only if the new ENDURO unit that has been selected in this way has a service factor $f_s \geq 1$ in the performance tables.

From another point of view, the value of f_s in

the performance tables refers to a case in which the effective torque requested by the application M_{r2} matches perfectly with the one appearing on the catalogue M_{n2} .

Whenever the torque indicated in the performance table is higher than the requested one, the offered service factor of the performance table can be increased according to the formula:

$$f_{s \text{ real}} = \frac{f_s \text{ on the table} \cdot M_{n2} \text{ on the table}}{M_{r2}}$$

The value of f_s calculated in this way must be $\geq f_{sr}$.

Each ENDURO is supplied with long-life synthetic oil and do not require any maintenance. The oil quantity is suitable for B3 mounting position

ENDURO	Oil (ltr)						ISO	Temp.	Oil Type
	B3	B6	B7	B8	V5	V6			
EN020	0.37	1.20	1.20	1.25	1.40	1.00	VG 220	-25 +80°C	Mobil SHC 630 Shell Tivela S220 Klubersynth GH6-220
EN040	0.65	2.00	2.00	2.10	1.90	1.85			
EN060	0.90	2.90	2.90	3.00	2.80	2.50			
EN150	1.60	5.70	5.80	6.60	6.80	5.50			
EN270	2.50	10.00	10.30	10.80	10.40	9.10			
EN430	5.80	17.60	18.20	20.00	20.50	16.50			

After adapting the oil quantity, each ENDURO can be mounted in ANY position, thus giving big advantages in the stock management and lead time, thanks to the following 3 characteristics:



1 ZZ per-lubricated bearings on input and output shaft

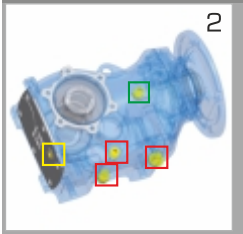

2 5 interchangeable plugs, including one breather plug and a level plug. Level and breather plug must be positioned according to this chart



3 Mechanical parts locked in their positions by circlips. This also ensures better absorption of axial thrust and prolongs the life of bearings

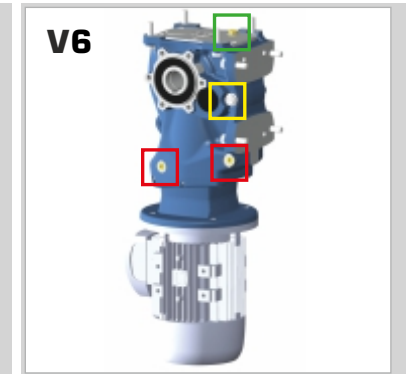
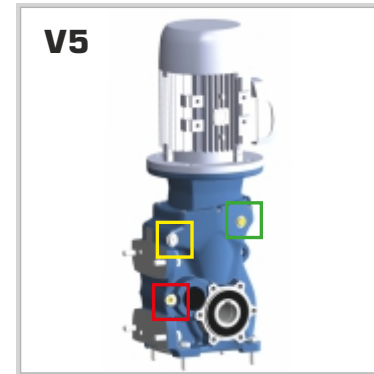
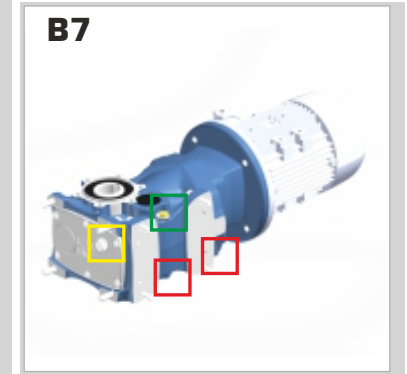
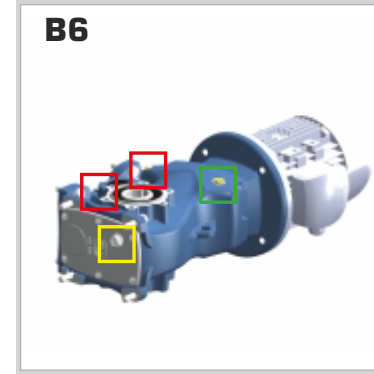
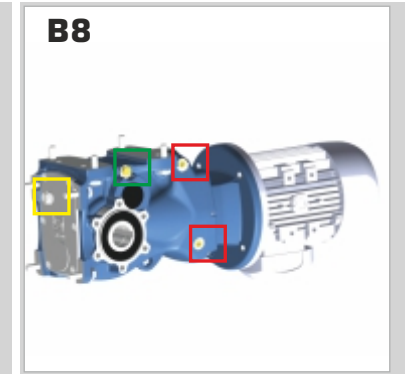
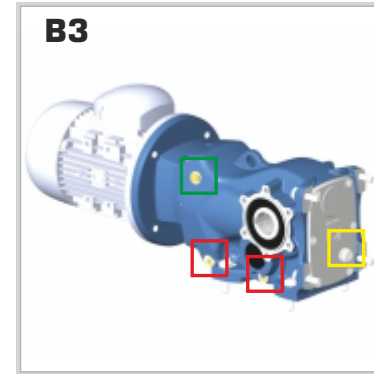

breather plug



level plug



filler plug

PERFORMANCE TABLE

Peak torque = 230 Nm																						
ENDURO020																						
Input: 63, 71, 80, 90, 100, 112	Rated ratio	4	5	7	10	13	17	20	25	30	32	35	40	50	55	60	75	90	100	110	120	
	Real ratio	4.73	5.76	8.86	11.09	13.53	17.24	20.56	26.04	31.0	32.19	33.18	39.27	50.05	55.18	59.67	75.58	92.84	96.33	106.21	115.07	
	Stages	3	3	3	3	3	3	3	3	3	3	3	3	3	3	3	3	3	3	3	3	
	ENDURO 020 with 2 pole / 2880 RPM motors																					
	kW	Frame	Torque (Nm)																			
	Speed (rpm)		608.9	500.0	325.1	259.7	212.9	167.1	140.1	110.6	92.9	89.5	86.8	73.3	57.5	52.2	48.3	38.1	31.0	29.9	27.1	25.0
	0.18	63A	2.7	3.2	5.0	6.2	7.6	9.7	11.5	14.6	17.4	18.1	18.6	22.0	28.1	31.0	33.5	42.4	52.1	54.0	59.6	64.6
	0.25	63B	3.7	4.5	6.9	8.6	10.5	13.4	16.0	20.3	24.2	25.1	25.9	30.6	39.0	43.0	46.5	58.9	72.3	75.1	82.8	89.7
	0.37	71A	5.5	6.6	10.2	12.8	15.6	19.9	23.7	30.0	35.8	37.1	38.3	45.3	57.7	63.6	68.8	87.2	107.1	111.1	122.5	132.7
	0.55	71B	8.1	9.9	15.2	19.0	23.2	29.6	35.2	44.6	53.1	55.2	56.9	67.3	85.8	94.6	102.3	129.6	159.2	165.1	182.1	197.3
0.75	80A	11.1	13.5	20.7	25.9	31.6	40.3	48.1	60.9	72.5	75.3	77.6	91.8	117.0	129.0	139.5	176.7	217.0		ENDURO 040		
1.1	80B	16.2	19.7	30.4	38.0	46.4	59.1	70.5	89.3	106.3	110.4	113.8	134.6	171.6	189.2	204.6	ENDURO 040			EN060		
1.5	90S	22.1	26.9	41.4	51.9	63.3	80.6	96.1	121.8	144.9	150.5	ENDURO 040		ENDURO 060			ENDURO 150					
2.2	90L	32.4	39.5	60.8	76.0	92.8	118.2	141.0	178.6	212.6	220.7	ENDURO 040		ENDURO 060			ENDURO 150					
3.7	100L	54.6	66.4	ENDURO 040						ENDURO 060		ENDURO 150						ENDURO 270				
ENDURO 020 with 4 pole / 1440 RPM motors																						
Output flange: Ø160	Speed (rpm)	304.4	250.0	162.5	129.8	106.4	83.5	70.0	55.3	46.5	44.7	43.4	36.7	28.8	26.1	24.1	19.1	15.5	14.9	13.6	12.5	
	0.12	63A	3.5	4.3	6.6	8.3	10.1	12.9	15.4	19.5	23.2	24.1	24.8	29.4	37.4	41.3	44.6	56.5	69.5	72.1	79.5	86.1
	0.18	63B	5.3	6.5	9.9	12.4	15.2	19.3	23.1	29.2	34.8	36.1	37.2	44.1	56.2	61.9	67.0	84.8	104.2	108.1	119.2	129.1
	0.25	71A	7.4	9.0	13.8	17.3	21.1	26.9	32.0	40.6	48.3	50.2	51.7	61.2	78.0	86.0	93.0	117.8	144.7	150.1	165.5	179.3
	0.37	71B	10.9	13.3	20.4	25.6	31.2	39.8	47.4	60.1	71.5	74.2	76.5	90.6	115.4	127.3	137.6	174.3	214.1	222.2	ENDURO 040	
	0.55	80A	16.2	19.7	30.4	38.0	46.4	59.1	70.5	89.3	106.3	110.4	113.8	134.6	171.6	189.2	204.6	ENDURO 040			EN060	
	0.75	80B	22.1	26.9	41.4	51.9	63.3	80.6	96.1	121.8	144.9	150.5	155.1	183.6	ENDURO 040			ENDURO 060				
	1.1	90S	32.4	39.5	60.8	76.0	92.8	118.2	141.0	178.6	212.6	220.7	ENDURO 040		ENDURO 060			ENDURO 150				
	1.5	90L	44.2	53.9	82.9	103.7	126.5	161.2	192.3	ENDURO 040				ENDURO 060			ENDURO 150					
	2.2	100LA	64.9	79.0	ENDURO 040						ENDURO 060		ENDURO 150						ENDURO 270			
3.7	112M	109.1	132.9	ENDURO 040			ENDURO 060			ENDURO 150						ENDURO 270			EN430			
ENDURO 020 with 6 pole / 960 RPM motors																						
Hollow o/p shaft: 30	Speed (rpm)	203.0	166.7	108.4	86.6	71.0	55.7	46.7	36.9	31.0	29.8	28.9	24.4	19.2	17.4	16.1	12.7	10.3	10.0	9.0	8.3	
	0.18	71A	8.0	9.7	14.9	18.7	22.8	29.0	34.6	43.8	52.2	54.2	55.8	66.1	84.2	92.9	100.4	127.2	156.3	162.1	178.8	193.7
	0.25	71B	11.1	13.5	20.7	25.9	31.6	40.3	48.1	60.9	72.5	75.3	77.6	91.8	117.0	129.0	139.5	176.7	217.0	ENDURO 040		
	0.37	80A	16.4	19.9	30.7	38.4	46.8	59.6	71.1	90.1	107.3	111.4	114.8	135.9	173.2	190.9	206.5	ENDURO 040			EN060	
	0.55	80B	24.3	29.6	45.6	57.0	69.6	88.6	105.7	133.9	159.4	165.6	170.6	202.0	ENDURO 040			ENDURO 060			EN150	
	0.75	90S	33.2	40.4	62.1	77.8	94.9	120.9	144.2	182.6	217.4	225.8	ENDURO 040		ENDURO 060			ENDURO 150				
	1.1	90L	48.7	59.2	91.1	114.1	139.2	177.3	211.5	ENDURO 040				ENDURO 060			ENDURO 150					
	1.5	100L	66.3	80.8	ENDURO 040						ENDURO 060		ENDURO 150						ENDURO 270			
	2.2	112M	97.3	118.5	ENDURO 040				ENDURO 060		ENDURO 150						ENDURO 270					

EN020 : Input 90 available upto 32 ratio;
Input 100 & 112 available upto 5 ratio

PERFORMANCE TABLE

ENDURO 040																						Peak torque= 400Nm						
Input: 71, 80, 90, 100, 112	Rated ratio	4	5	7	10	13	15	16	18	20	25	30	35	40	50	55	60	70	75	85	100	110	120					
	Real ratio	4.73	5.85	7.11	9.95	13.13	14.25	16.22	18.36	20.65	26.3	29.93	37.5	41.36	47.08	53.29	58.99	71.78	76.33	86.89	96.6	108.86	116.81					
	Stages	3	3	3	3	3	3	3	3	3	3	3	3	3	3	3	3	3	3	3	3	3	3					
	ENDURO 040 with 2 pole / 2880 RPM motors																											
	kW	Frame	Torque (Nm)																									
	Speed (rpm)		608.9	492.3	405.1	289.4	219.3	202.1	177.6	156.9	139.5	109.5	96.2	76.8	69.6	61.2	54.0	48.8	40.1	37.7	33.1	29.8	26.5	24.7				
	0.37	71A	ENDURO 020																									
	0.55	71B	ENDURO 020																									
	0.75	80A	ENDURO 020																									
	1.1	80B	ENDURO 020																		246.1	261.7	297.9	331.2	373.2	EN060		
1.5	90S	ENDURO 020											175.3	193.4	ENDURO 060				ENDURO 150									
2.2	90L	ENDURO 020											257.2	283.6	ENDURO 060				ENDURO 150									
3.7	100L	ENDURO 020	82.0	114.8	151.4	164.3	187.1	211.7	238.2	303.3	345.2	EN060	ENDURO 150								ENDURO 270							
Output flange: Ø200	ENDURO 040 with 4 pole / 1440 RPM motors																											
	Speed (rpm)		304.4	246.2	202.5	144.7	109.7	101.1	88.8	78.4	69.7	54.8	48.1	38.4	34.8	30.6	27.0	24.4	20.1	18.9	16.6	14.9	13.2	12.3				
	0.25	71A	ENDURO 020																									
	0.37	71B	ENDURO 020																									
	0.55	80A	ENDURO 020																		246.1	261.7	297.9	331.2	373.2	EN060		
	0.75	80B	ENDURO 020																		220.1	249.2	275.8	335.6	356.9	ENDURO 060		
	1.1	90S	ENDURO 020											257.2	283.6	ENDURO 060				ENDURO 150								
	1.5	90L	ENDURO 020											245.9	279.9	350.7	386.8	ENDURO 060			ENDURO 150							
	2.2	100L	ENDURO 020	97.5	136.5	180.1	195.4	222.5	251.8	283.2	360.7	ENDURO 060	ENDURO 150								ENDURO 270							
	3.7	112M	ENDURO 020	164.0	229.5	302.9	328.7	374.1	ENDURO 060	ENDURO 150						ENDURO 270						EN430						
Hollow o/p shaft: 35	ENDURO 040 with 6 pole / 960 RPM motors																											
	Speed (rpm)		203.0	164.1	135.0	96.5	73.1	67.4	59.2	52.3	46.5	36.5	32.1	25.6	23.2	20.4	18.0	16.3	13.4	12.6	11.0	9.9	8.8	8.2				
	0.18	71A	ENDURO 020																									
	0.25	71B	ENDURO 020																									
	0.37	80A	ENDURO 020																		248.4	264.1	300.6	334.2	376.6	EN060		
	0.55	80B	ENDURO 020																		242.1	274.1	303.4	369.2	392.6	ENDURO 060		
	0.75	90S	33.2	41.0	49.9	69.8	92.1	99.9	113.8	128.8	144.8	184.4	209.9	263.0	290.1	ENDURO 060				ENDURO 150								
	1.1	90L	48.7	60.2	73.1	102.3	135.1	146.6	166.8	188.9	212.4	270.5	307.9	385.7	ENDURO 060			ENDURO 150										
1.5	100L	66.3	82.1	99.7	139.6	184.2	199.9	227.5	257.5	289.6	368.9	ENDURO 060	ENDURO 150						ENDURO 270									
2.2	112M	97.3	120.3	146.3	204.7	270.1	293.2	333.7	377.7	ENDURO 060	ENDURO 150						ENDURO 270											

EN040 : Input 90 available upto 40 ratio;
Input 100 & 112 available upto 30 ratio

PERFORMANCE TABLE

Peak torque = 600 Nm																													
ENDURO060																													
Input: 71, 80, 90, 100, 112	Rated ratio	4	5	7	10	13	16	18	20	22	23	25	28	30	35	38	40	43	45	50	55	60	65	85	95	100	110	120	
	Real ratio	4.21	5.20	8.32	11.00	12.75	16.50	18.73	21.04	22.24	23.18	25.76	27.82	32.22	33.35	37.85	41.71	42.53	46.84	47.35	56.22	58.59	65.13	84.31	95.7	102.4	108.3	118.4	
	Stages	3	3	3	3	3	3	3	3	3	3	3	3	3	3	3	3	3	3	3	3	3	3	3	3	3	3	3	
	ENDURO 060 with 2 pole / 2880 RPM motors																												
	kW	Frame	Torque (Nm)																										
	Speed (rpm)		684.1	553.8	346.2	261.8	225.9	174.5	153.8	136.9	129.5	124.2	111.8	103.5	89.4	86.4	76.1	69.0	67.7	61.5	60.8	51.2	49.2	44.2	34.2	30.1	28.1	26.6	24.3
	0.37	71A	ENDURO 020																										
	0.55	71B	ENDURO 020																										
	0.75	80A	ENDURO 020																				ENDURO 040						
	1.1	80B	ENDURO 020																		ENDURO 040				406.1				
1.5	90S	ENDURO 020												ENDURO 040				198.8	219.0	221.4	262.9	273.9	304.5	394.2	ENDURO 150				
2.2	90L	ENDURO 020												ENDURO 040				291.6	321.2	324.7	385.5	401.8	446.6	578.1	ENDURO 150				
3.7	100L	ENDURO 020		ENDURO 040										384.6		ENDURO 150										ENDURO 270			
ENDURO 060 with 4 pole / 1440 RPM motors																													
Speed (rpm)		342.0	276.9	173.1	130.9	112.9	87.3	76.9	68.4	64.7	62.1	55.9	51.8	44.7	43.2	38.0	34.5	33.9	30.7	30.4	25.6	24.6	22.1	17.1	15.0	14.1	13.3	12.2	
0.25	71A	ENDURO 020																											
0.37	71B	ENDURO 020																											
0.55	80A	ENDURO 020																				ENDURO 040				371.3	406.1		
0.75	80B	ENDURO 020																ENDURO 040				394.2	447.4	478.5	506.3	553.7			
1.1	90S	ENDURO 020												ENDURO 040				401.8	446.6	578.1	ENDURO 150								
1.5	90L	ENDURO 020								ENDURO 040								397.7	438.0	442.8	525.7	547.9	ENDURO 150						
2.2	100L	ENDURO 020		ENDURO 040										381.5	441.9	457.4	ENDURO 150										ENDURO 270		
3.7	112M	ENDURO 020		ENDURO 040						432.0	485.3	513.0	534.7	594.2	ENDURO 150										ENDURO 270		EN430		
ENDURO 060 with 6 pole / 960 RPM motors																													
Speed (rpm)		228.0	184.6	115.4	87.3	75.3	58.2	51.3	45.6	43.2	41.4	37.3	34.5	29.8	28.8	25.4	23.0	22.6	20.5	20.3	17.1	16.4	14.7	11.4	10.0	9.4	8.9	8.1	
0.18	71A	ENDURO 020																											
0.25	71B	ENDURO 020																											
0.37	80A	ENDURO 020																				ENDURO 040				409.8			
0.55	80B	ENDURO 020																ENDURO 040				433.6	492.2	526.4	556.9	EN150			
0.75	90S	ENDURO 020												ENDURO 040				298.3	328.5	332.1	394.3	410.9	456.8	591.3	ENDURO 150				
1.1	90L	ENDURO 020								ENDURO 040								389.3	429.0	437.5	481.8	487.0	578.3	ENDURO 150					
1.5	100L	ENDURO 020		ENDURO 040										390.2	451.9	467.8	ENDURO 150										ENDURO 270		
2.2	112M	ENDURO 020		ENDURO 040						432.8	457.5	476.9	529.9	572.3	ENDURO 150										ENDURO 270				

EN060 : Input 90 available upto 85 ratio;
 Input 100 & 112 available upto 35 ratio

PERFORMANCE TABLE

ENDURO 150																										Peak torque = 1550 Nm									
Input: 90, 100, 112, 132	Rated ratio	7	8	10	13	14	16	18	21	23	24	25	30	35	40	45	47	50	53	58	60	65	75	80	90	100	110	115							
	Real ratio	7.04	8.40	10.0	12.6	14.2	15.7	17.9	21.3	23.1	24.0	25.2	29.7	34.6	40.3	45.2	47.1	50.0	53.8	58.4	60.8	64.1	75.0	80.7	87.6	100.7	109.3	113.8							
	Stages	3	3	3	3	3	3	3	3	3	3	3	3	3	3	3	3	3	3	3	3	3	3	3	3	3	3	3							
	ENDURO 150 with 2 pole / 2880 RPM motors																																		
	kW	Frame	Torque (Nm)																																
	Speed (rpm)		409.0	342.8	289.2	228.6	203.2	183.1	161.2	135.4	124.7	119.8	114.4	97.1	83.1	71.6	63.8	61.1	57.6	53.6	49.3	47.4	45.0	38.4	35.7	32.9	28.6	26.3	25.3						
	1.5	90S	ENDURO 020												ENDURO 040						ENDURO 060						409.5	470.7	511.0	532.0					
	2.2	90L	ENDURO 020												ENDURO 040						ENDURO 060						600.6	690.3	749.5	780.3					
	3.7	100L	ENDURO 040												EN060	464.2	520.9	543.4	576.4	620.2	673.4	701.1	738.8	864.6	930.4	1010	1161	ENDURO 270							
	5.5	132SA	120.7	144.0	170.8	216.0	242.9	269.6	306.4	364.6	396.0	412.2	431.6	508.3	593.9	ENDURO 270						ENDURO 430													
7.5	132SB	164.6	196.4	232.8	294.6	331.3	367.7	417.8	497.2	540.0	562.1	588.5	693.1	809.8	ENDURO 270						ENDURO 430														
Output flange: Ø300	ENDURO 150 with 4 pole / 1440 RPM motors																																		
	Speed (rpm)		204.5	171.4	144.6	114.3	101.6	91.6	80.6	67.7	62.3	59.9	57.2	48.6	41.6	35.8	31.9	30.6	28.8	26.8	24.7	23.7	22.5	19.2	17.9	16.4	14.3	13.2	12.7						
	1.1	90S	ENDURO 020												ENDURO 040						ENDURO 060						600.6	690.3	749.5	780.3					
	1.5	90L	ENDURO 020												ENDURO 040						ENDURO 060						599.0	701.0	754.3	819.1	941.3	1022	1064		
	2.2	100L	ENDURO 040												ENDURO 060						552.0	619.5	646.2	685.5	737.6	800.8	833.7	878.6	1028	1106	1201	1381	ENDURO 270		
	3.7	112M	ENDURO 040												ENDURO 060						683.9	799.0	928.4	1042	1087	1153	1240	1347	1402	1478	ENDURO 270			ENDURO 430	
	5.5	132S	241.4	288.1	341.5	432.0	485.8	539.2	612.7	729.3	792.0	824.4	863.1	1017	1188	ENDURO 270						ENDURO 430													
7.5	132M	329.2	392.8	465.7	589.1	662.5	735.3	835.5	994.5	1080	1124	1177	1386	ENDURO 270						ENDURO 430															
Hollow o/p Shaft: 50	ENDURO 150 with 6 pole / 960 RPM motors																																		
	Speed (rpm)		136.3	114.3	96.4	76.2	67.7	61.0	53.7	45.1	41.6	39.9	38.1	32.4	27.7	23.9	21.3	20.4	19.2	17.9	16.4	15.8	15.0	12.8	11.9	11.0	9.5	8.8	8.4						
	0.75	90S	ENDURO 020												ENDURO 040						ENDURO 060						614.3	706.0	766.6	798.0					
	1.1	90L	ENDURO 020												ENDURO 040						ENDURO 060						600.6	625.3	658.9	771.2	829.8	901.0	1035	1124	1170
	1.5	100L	ENDURO 040												ENDURO 060						564.6	633.6	660.9	701.0	754.3	819.0	852.7	898.5	1052	1132	1229	1412	ENDURO 270		
	2.2	112M	ENDURO 040												ENDURO 060						610.0	712.6	828.0	929.3	969.4	1028	1106	1201	1251	1318	ENDURO 270			ENDURO 430	
3.7	132S	243.6	290.7	344.6	435.9	490.3	544.1	618.3	735.9	799.2	831.9	871.0	1026	1199	ENDURO 270						ENDURO 430														
5.5	132M	362.1	432.1	512.3	648.0	728.8	808.8	919.1	1094	1188	1237	1295	1525	ENDURO 270						ENDURO 430															

EN150 : Input 100 available upto 100 ratio;
 Input 112 available upto 65 ratio; Input 132 available upto 35 ratio

PERFORMANCE TABLE

Peak torque = 2700 Nm																										
ENDURO 270																										
Input: 90, 100, 112, 132, 160	Rated ratio	7	10	12	16	18	20	22	23	25	28	30	33	40	43	45	50	53	57	65	72	85	95	110	120	
	Real ratio	6.53	9.04	11.19	15.10	17.71	19.59	22.34	22.86	25.34	28.30	28.98	33.35	41.87	43.31	44.79	49.53	53.63	57.00	64.07	72.35	85.19	93.84	108.0	121.4	
	Stages	3	3	3	3	3	3	3	3	3	3	3	3	3	3	3	3	3	3	3	3	3	3	3	3	
	ENDURO 270 with 2 pole / 2880 RPM motors																									
	kW	Frame	Torque (Nm)																							
	Speed (rpm)		441.0	318.6	257.4	190.7	162.6	147.0	128.9	126.0	113.7	101.8	99.4	86.4	68.8	66.5	64.3	58.1	53.7	50.5	45.0	39.8	33.8	30.7	26.7	23.7
	1.5	90S	ENDURO 020											ENDURO 040		ENDURO 060						ENDURO 150				
	2.2	90L	ENDURO 020											ENDURO 040		ENDURO 060						ENDURO 150				
	3.7	100L	ENDURO 040											EN060		ENDURO 150						1246		1400		
	5.5	132SA	ENDURO 150											717.8		742.5	767.9	849.1	919.4	977.2	1098	1240	ENDURO430			
7.5	132SB	ENDURO 150											978.8		1012	1047	1158	1254	1333	1498	ENDURO 430					
11	160MA	223.9	310.0	383.7	517.7	607.2	671.7	766.0	783.8	868.8	970.3	993.6	1143	ENDURO430												
15	160MB	305.3	422.7	523.2	706.0	828.0	915.9	1045	1069	1185	1323	1355	1559	ENDURO430												
18.5	160L	376.6	521.3	645.3	870.7	1021	1130	1288	1318	1461	ENDURO 430															
ENDURO 270 with 4 pole / 1440 RPM motors																										
Speed (rpm)		220.5	159.3	128.7	95.4	81.3	73.5	64.5	63.0	56.8	50.9	49.7	43.2	34.4	33.2	32.2	29.1	26.9	25.3	22.5	19.9	16.9	15.3	13.3	11.9	
1.1	90S	ENDURO 020											ENDURO 040		ENDURO 060						ENDURO 150					
1.5	90L	ENDURO 020											ENDURO 040		ENDURO 060						ENDURO 150					
2.2	100L	ENDURO 040											ENDURO 060		ENDURO 150						1481		1665			
3.7	112M	ENDURO 040				ENDURO 060				ENDURO 150						1669		1965	2165	2491	EN430					
5.5	132S	ENDURO 150											1436		1485	1536	1698	1839	1954	2197	2481	ENDURO430				
7.5	132M	ENDURO 150											1559		1958	2025	2094	2316	2507	2665	ENDURO430					
11	160M	447.8	619.9	767.3	1035	1214	1343	1532	1568	1738	1941	1987	2287	ENDURO430												
15	160L	610.6	845.3	1046	1412	1656	1832	2089	2138	2370	2646	ENDURO430														
ENDURO 270 with 6 pole / 960 RPM motors																										
Speed (rpm)		147.0	106.2	85.8	63.6	54.2	49.0	43.0	42.0	37.9	33.9	33.1	28.8	22.9	22.2	21.4	19.4	17.9	16.8	15.0	13.3	11.3	10.2	8.9	7.9	
0.75	90S	ENDURO 020											ENDURO 040		ENDURO 060						ENDURO 150					
1.1	90L	ENDURO 020											ENDURO 040		ENDURO 060						ENDURO 150					
1.5	100L	ENDURO 040											ENDURO 060		ENDURO 150						1515		1703			
2.2	112M	ENDURO 040				ENDURO 060				ENDURO 150						1488		1753	1931	2222	2497					
3.7	132S	ENDURO 150											1449		1498	1550	1714	1856	1972	2217	2503	ENDURO430				
5.5	132M	ENDURO 150											1715		2153	2227	2304	2547	ENDURO430							
7.5	160M	458.0	634.0	784.8	1059	1242	1374	1567	1603	1777	1985	2032	2339	ENDURO430												
11	160L	671.7	929.9	1151	1553	1822	2015	2298	2351	2607	ENDURO430															

EN270 : Input 132 available upto 72 ratio;
 Input 160 available upto 35 ratio

PERFORMANCE TABLE

ENDURO 430		Peak torque = 4300 Nm																																																		
Input: 100, 112, 132, 160, 180	Rated ratio	7	8	11	14	15	17	18	20	21	25	28	30	33	35	40	45	50	53	60	65	70	75	85	95	110	120																									
	Real ratio	7.19	8.31	11.26	14.09	15.52	17.45	18.18	19.41	21.01	24.31	28.48	28.95	33.32	35.62	39.2	45.94	49.08	53.38	61.46	65.01	69.32	74.89	84.24	95.5	110.4	117.7																									
	Stages	3	3	3	3	3	3	3	3	3	3	3	3	3	3	3	3	3	3	3	3	3	3	3	3	3	3																									
	ENDURO 430 with 2 pole / 2880 RPM motors																																																			
	kW	Frame	Torque (Nm)																																																	
	Speed (rpm)		400.6	346.6	255.8	204.4	185.6	165.0	158.4	148.4	137.1	118.5	101.1	99.5	86.4	80.9	73.4	62.7	58.7	54.0	46.9	44.3	41.5	38.46	34.2	30.1	26.1	24.5																								
	3.7	100L	ENDURO 040											ENDURO 060				ENDURO 150								ENDURO 270																										
	5.5	132SA	ENDURO 150											ENDURO 270								1284			1444			1638																								
	7.5	132SB	ENDURO 150											ENDURO 270								1621			1751			1969			2233																					
	11	160MA	ENDURO 270											1221				1345			1575			1683			1830			2107																						
15	160MB	ENDURO 270											1665				1835			2148			2295			2496			2874																							
18.5	160L	ENDURO 270											1642			1669			1921			2054			2263			2649			2830			3078			3544															
22	180M	493.0	569.8	772.1	966.2	1064	1197	1247	1331	1441	1667	1953	1985	2285	2443																																					
Output flange: Ø450	ENDURO 430 with 4 pole / 1440 RPM motors																																																			
	Speed (rpm)		200.3	173.3	127.9	102.2	92.8	82.5	79.2	74.2	68.5	59.2	50.6	49.7	43.2	40.4	36.7	31.3	29.3	27.0	23.4	22.2	20.8	19.23	17.1	15.1	13.0	12.2																								
	2.2	100L	ENDURO 040											ENDURO 060				ENDURO 150								ENDURO 270																										
	3.7	112M	ENDURO 040											ENDURO 060				ENDURO 150								ENDURO 270			2715																							
	5.5	132S	ENDURO 150											ENDURO 270								2568			2888			3275																								
	7.5	132M	ENDURO 150											ENDURO 270								2874			3040			3241			3501			3939																		
	11	160M	ENDURO 270											2443				2691			3150			3366			3660			4215																						
	15	160L	ENDURO 270											2707			3116			3331			3669																													
	18.5	180M	829.2	958.3	1299	1625	1790	2013	2097	2239	2423	2804	3285	3339	3843	4108																																				
	22	180L	986.1	1140	1544	1932	2129	2393	2493	2662	2881	3334	3906	3970																																						
Hollow o/p Shaft: 70	ENDURO 430 with 6 pole / 960 RPM motors																																																			
	Speed (rpm)		133.5	115.5	85.3	68.1	61.9	55.0	52.8	49.5	45.7	39.5	33.7	33.2	28.8	27.0	24.5	20.9	19.6	18.0	15.6	14.8	13.8	12.82	11.4	10.0	8.7	8.2																								
	1.5	100L	ENDURO 040											ENDURO 060				ENDURO 150								ENDURO 270																										
	2.2	112M	ENDURO 040											ENDURO 060				ENDURO 150								ENDURO 270																										
	3.7	132S	ENDURO 150											ENDURO 270								2591			2915			3305																								
	5.5	132M	ENDURO 150											ENDURO 270								2745			3161																											
	7.5	160M	ENDURO 270											2498				2752			3222			3442			3744																									
	11	160L	ENDURO 270											2929			2978			3427			3664			4036																										
15	180L	1009	1165	1579	1976	2177	2448	2550	2723	2947	3410	3995	4061																																							

EN430 : Input 132 available upto 95 ratio; Input 160 available upto 60 ratio; Input 180 available upto 35 ratio

Note : Efficiency is computed considering the frictional losses of output seals, bearing frictional losses and lubrication losses. Torque increase by 3% in 2 stage gearboxes and 5% in 3 stage gearboxes if these losses are not considered.

LIST OF COMPONENTS

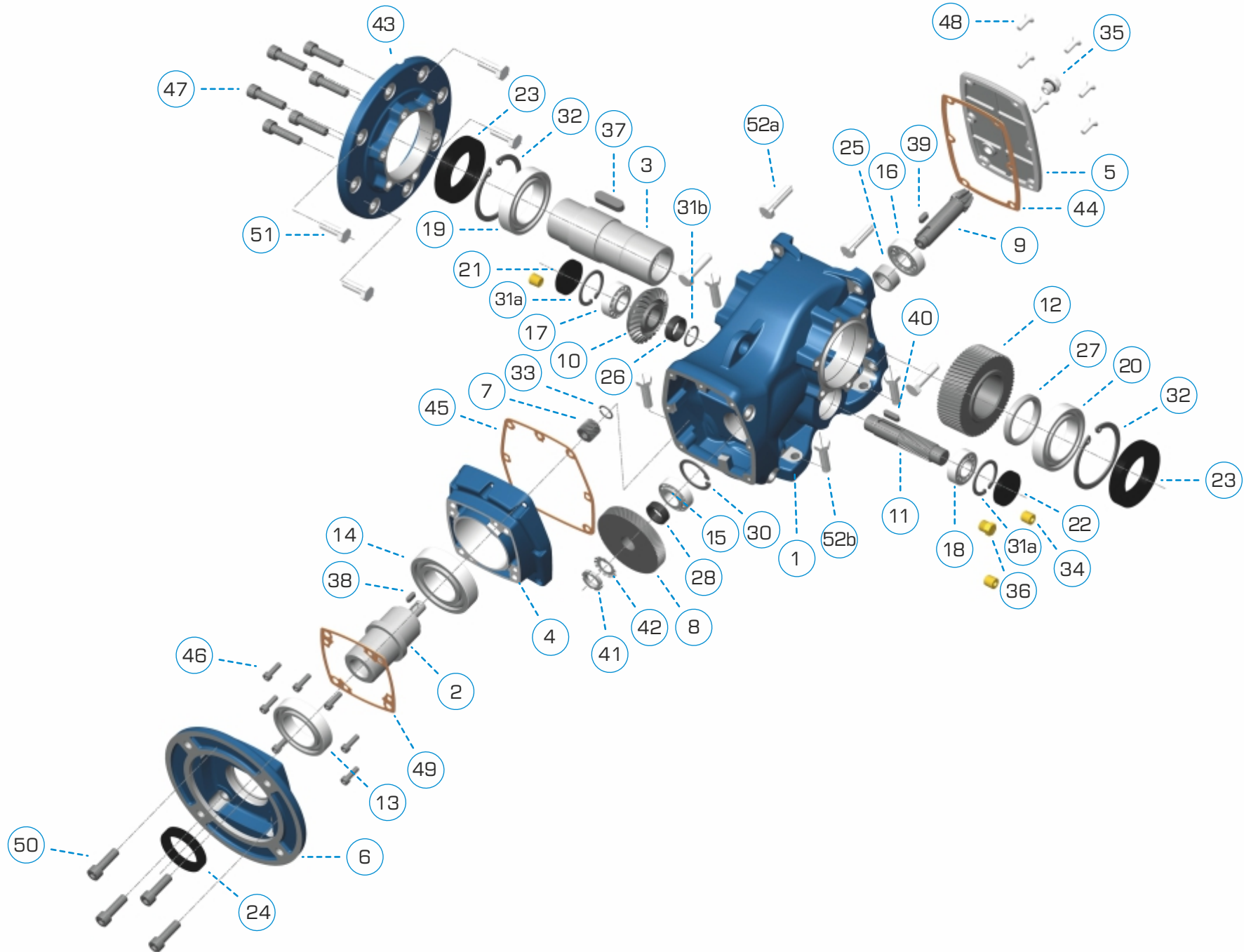

DIMENSIONS

ENDURO	Motor type		Nm	Mm	Pm	Sm	Dm	tm	bm	L (PAM)
020	63	B5	95	115	140	10	11	12.8	4	264.5
	71	B5	110	130	160	M8	14	16.3	5	
	80	B5	130	165	200	M10	19	21.8	6	
	90	B5	130	165	200	M10	24	27.3	8	
040	100/112	B5	180	215	250	M12	28	31.3	8	271.5
	71	B5	110	130	160	M8	14	16.3	5	
	80	B5	130	165	200	M10	19	21.8	6	
	90	B5	130	165	200	M10	24	27.3	8	
060	100/112	B5	180	215	250	M12	28	31.3	8	319.5
	71	B5	110	130	160	M8	14	16.3	5	
	80	B5	130	165	200	M10	19	21.8	6	
	90	B5	130	165	200	M10	24	27.3	8	
150	100/112	B5	180	215	250	M12	28	31.3	8	409.5
	90	B5	130	165	200	M10	24	27.3	8	
	100/112	B5	180	215	250	M12	28	31.3	8	
	132	B5	230	265	300	M12	38	41.3	12	
270	90	B5	130	165	200	M10	24	27.3	8	459
	100/112	B5	180	215	250	M12	28	31.3	8	
	132	B5	230	265	300	M12	38	41.3	12	
	160	B5	250	300	350	M16	42	45.3	12	
430	100/112	B5	180	215	250	M12	28	31.3	8	530
	132	B5	230	265	300	M12	38	41.3	12	
	160	B5	250	300	350	M16	42	45.3	12	
	180	B5	250	300	350	M16	48	51.8	14	

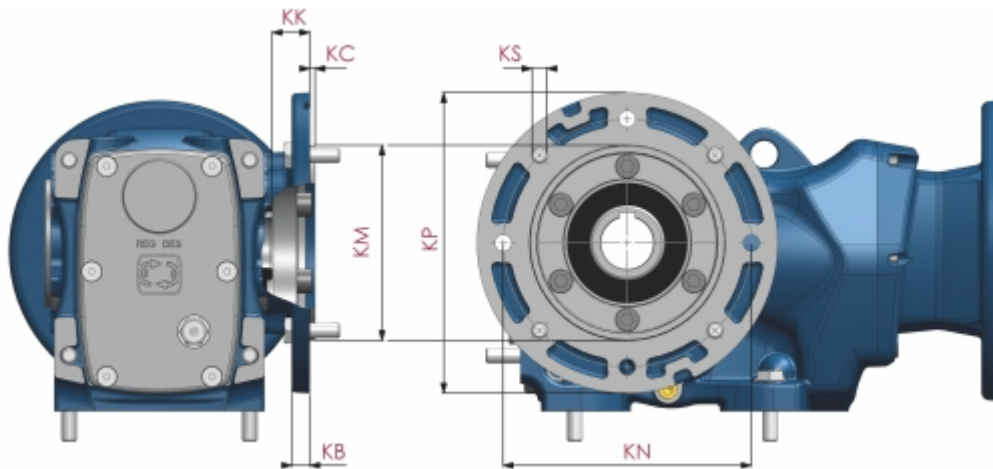
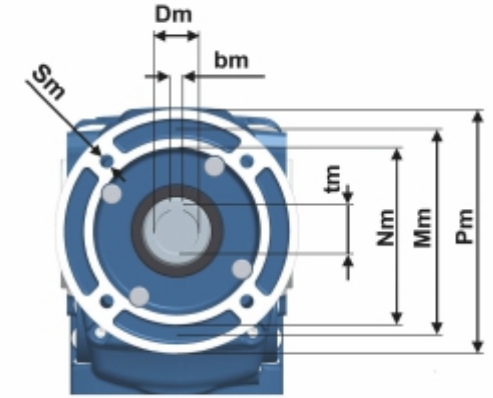
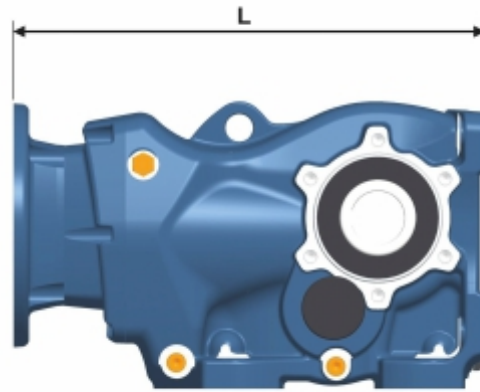

Flange Mounting

ENDURO	OFL	IEC	KP	KM (j6)	KN	KS	KK	KB	KC (0; -0,5)
020	OFL160	71B5	160	110	130	M8x30	24	10	3.5
040	OFL200	80/90B5	200	130	165	M10x30	25	12	3.5
060	OFL250	100/112B5	250	180	215	M12x40	23.5	12	4
150	OFL300	132B5	300	230	265	M12x45	37	18	4
270	OFL350	160/180B5	350	250	300	M16x50	30	18	4
430	OFL450	225B5	450	350	400	M16x55	42	23	5

DIMENSIONS

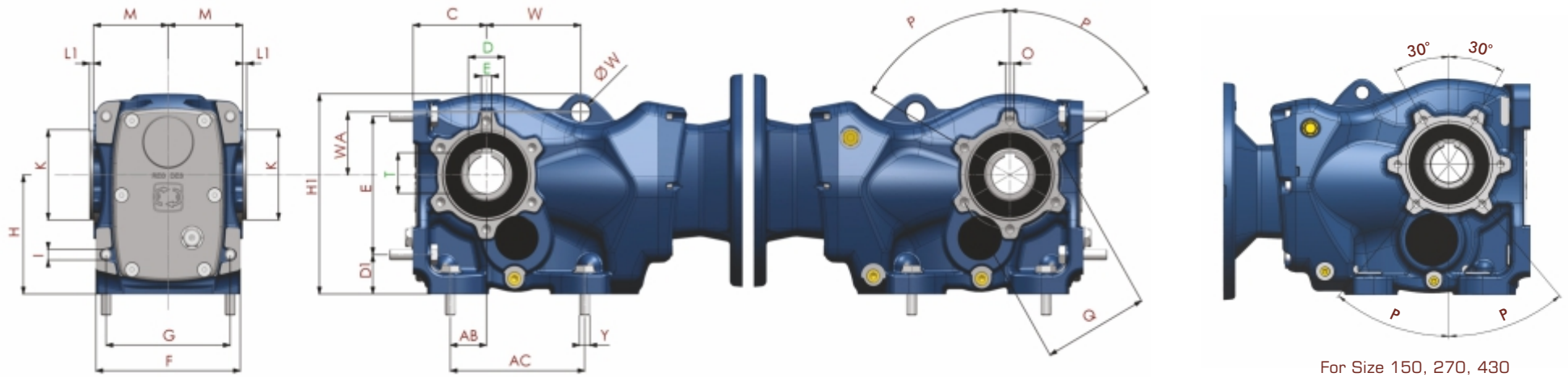

Foot Mounting

ENDURO	A	AB	AC	B	BA	BB	C	D1	E	F	G	H	H1	I	J	K (Ø h8)	L	L1	M	N	NA	NB	NC	O	P	Q	Y	ØW	W	WA
020	100	28	110	60	35	82	63	32	115	119	100	100	165	M10x30	M10	80	2	2.6	58	149	50.5	49	41	M8	60°	94	M10x35	15	75	50
040	120	35	130	70	40	100	71	37	130	140	120	112	188	M10x40	M10	85	3	4	72	204	57	59.5	85.5	M10	60°	102	M10x40	18	91	59
060	130	30	130	88	47	105	80	45	150	158	130	132	218	M12x40	M12	105	3	3	80	200	65	66	65	M12	60°	125	M12x45	20	100	65
150	165	40	150	102	48	122	112	55	200	200	165	180	295	M16x55	M16	120	4.5	4.5	101	236	92	86	73	M12	40°	142	M16x60	18	120	99
270	180	55	180	118	65	160	132	70	233	230	180	212	348	M20x65	M16	140	4	4	116	293	113	93	94	M16	45°	178	M20x70	18	140	116
430	240	75	240	160	83	165	160	75	295	290	240	265	418	M24x75	M20	185	4.5	4.5	145	355	141	125	111	M16	45°	220	M24x80	25	154	128

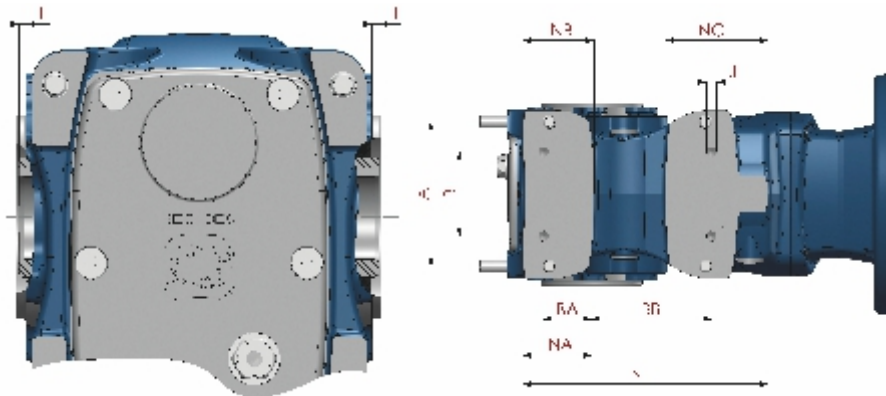

Standard Output Shaft

ENDURO	ØD1	ØD (H7)	B0 (+0,2;0)	T5	T6	V	T (+0,2;0)	E (E9)
020	45	30	120	15	15	M10x25	33.3	8
040	50	35	150	18	18	M12x30	38.5	10
060	55	40	166	24	24	M16x40	43.3	12
150	70	50	210	27	27	M16x45	53.8	14
270	85	60	240	30	30	M20x50	64.5	18
430	95	70	300	30	30	M20x50	74.9	20

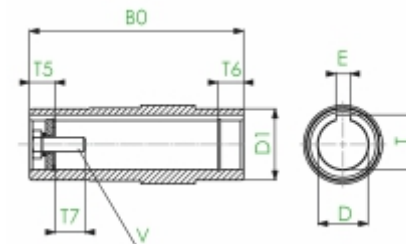

DIMENSIONS

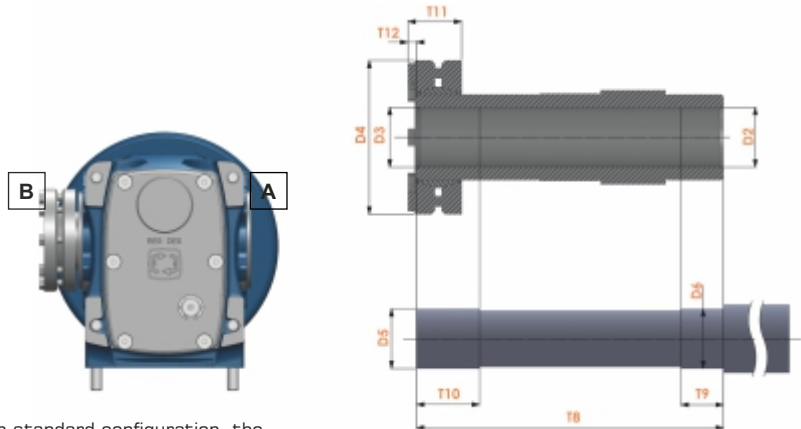

In standard configuration, the shrink disc is mounted on B side

Shrink disc shaft

ENDURO	D2 (ØH7)	D3 (ØH7)	D4 (Ø)	D5 (Øh6)	ØD6 (h6)	T8 (±0,1)	T9	T10	T11	T12
020	30	30	80	30	30	150	20	31	24.2	5.3
040	35	35	90	35	35	180	20	32	26.1	5.3
060	40	40	100	40	40	200	20	26	29	5.3
150	50	50	138	50	50	241	30	36	37.3	5.3
270	65	65	155	65	65	281	40	41	44.3	5.3
430	75	75	170	75	75	345	50	55	49.3	5.3

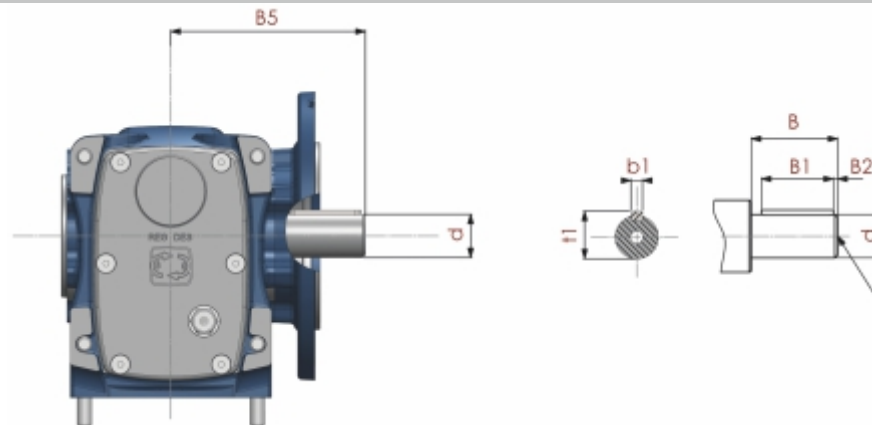

Single and double output shaft

ENDURO	d (h6)	B	B1	B2	B3	B4	B5	b1	t1	f
020	25	50	40	5	110	60	134	8	28	M10x20
040	30	60	50	3	135	75	160	8	33	M10x20
060	35	70	56	5	153	88	176.5	10	38	M12x24
150	50	100	80	10	206	123.5	242	14	44.5	M16x32
270	60	120	100	5	240	150	270	18	53	M20x40
430	70	140	125	7.5	291	171	332	20	62.5	M20x40

Torque Arm

ENDURO	T1	T2	T3	T4	T5	R	α	M	T6	T7	d ± 0.08
020	100	10	140	20	23.5	22.5	60	n°4 M10	36	31	Ø10,4
040	112	12	160	20	30	22.5	55	n°4 M10	36	31	Ø10,4
060	132	13	192	18	40	29	55	n°4 M12	60	54	Ø16,4
150	180	20	250	25	52.5	29	60	n°4 M16	60	54	Ø16,4
270	212	25	300	30	60	41	60	n°4 M16	80	72	Ø25
430	265	25	350	40	70	41	50	n°4 M20	100	92	Ø25

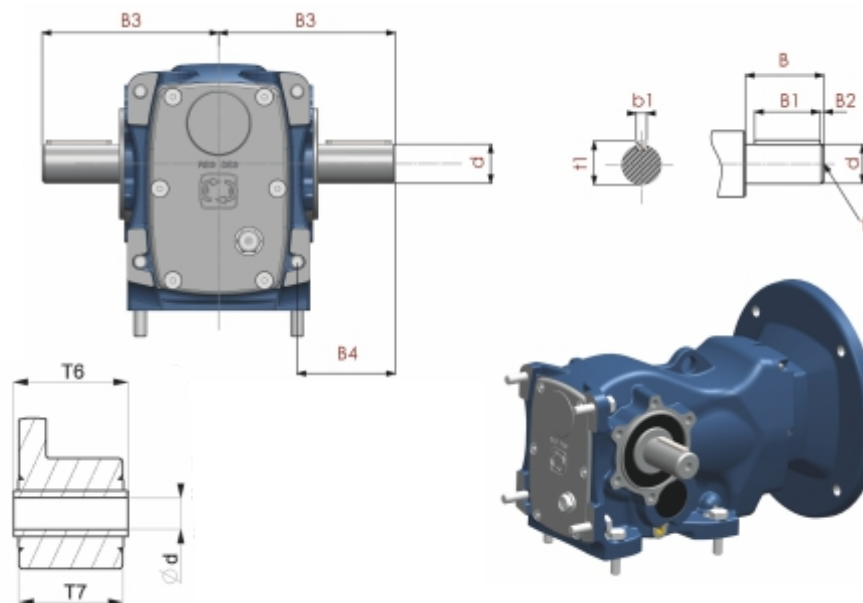
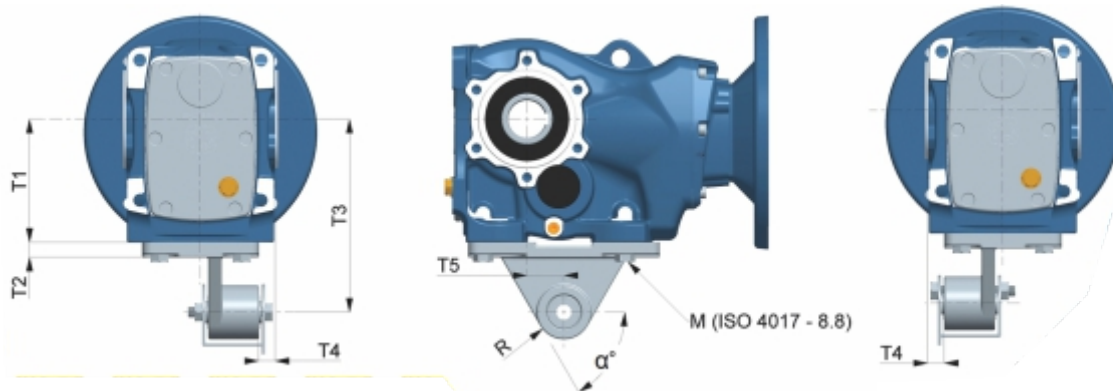



CMM for Mechanical Inspection



Gear Lead & Profile Tester

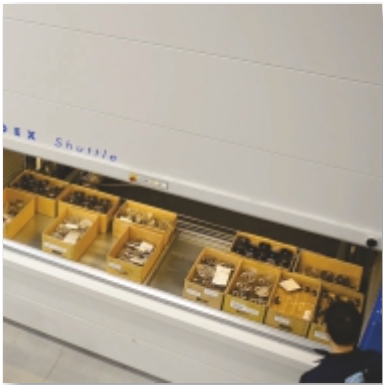

KARDEX for Gear Storage

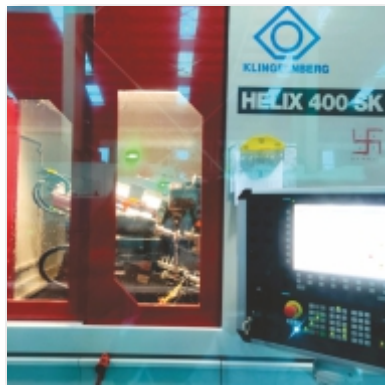

Gear Profile Grinding



Magnifying Glass to Check Gear



Gearbox Machining

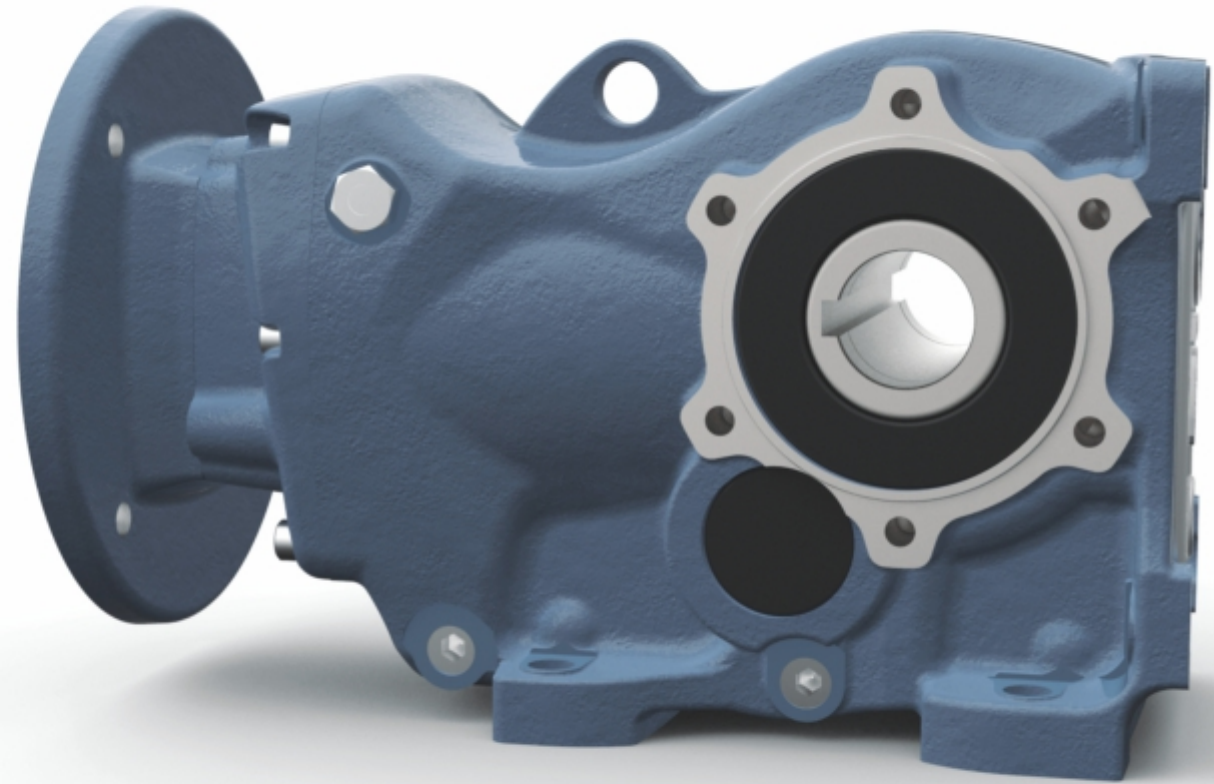

All information and data presented in this catalogue have been checked with greatest care. We however do not assume responsible for any unintended errors and omissions. Our designs are being continuously improved, so please reconfirm specifications and dimensions prior to ordering.

Regional Sales Offices:

Rotomotive Ahmedabad

Rotomotive Powerdrives India Ltd.
Regional Office: Shridhar Bunglows
No.14, Nr. Mansarover Tenament
Nr. Arpan School, Nirang Cross Rd.
PO. Vastral, Ahmedabad - 382 418
Tel/Fax No: +91-79-29093837
Cell No.: +91 93746 31145
E-mail: sales.ahd@rotomotive.com

Rotomotive Delhi

305, 3rd Floor, Nipun Tower,
Plot no. 15, Karkardooma Community Center,
Delhi - 110092
Tel No. : 011447007139
Cell No. : 93123 54230
Email : sales.delhi@rotomotive.com

Rotomotive Mumbai

Rotomotive Powerdrives India Ltd.
303 Swastik Disa Corporate Park,
Lal Bahadur Shastri Marg,
Opposite Shreyas Cinema,
Ghatkopar (W), Mumbai - 400086
Cell No.: +91 90237 27849
E-mail: sales.mum@rotomotive.com

Rotomotive Secunderabad

Rotomotive Powerdrives India Ltd.
No 6013, VI Floor, Emerald House
S.D. Road, Secunderabad - 500 003
Cell No.: 093466 16807
E-mail: sales.sec@rotomotive.com

Rotomotive Bangalore

Rotomotive Powerdrives India Ltd.
Asha Chambers, F15, #2 (Old # 33)
Venkataswamy Raju road, Kumarapark West
Bangalore - 560020
Tel:+91- 80 - 23465240/23465241
Fax: +91 - 80 - 4147 9547
Cell No.: +91 93437 04949 / 93421 61610
E-mail: sales.blr@rotomotive.com

Rotomotive Pune

Rotomotive Powerdrives India Ltd.
Plot No 425/77, T.M.V Colony,
Opposite Katariya High School
Gultekdi, Pune - 411037
Cell No.: +91 87888 32719 / 90288 60832
E-mail: sales.pune@rotomotive.com



Rotomotive Powerdrives India Ltd.

223, Napa Talpad, Gana-Borsad Road,
Tal: Borsad, Anand, Gujarat - 388 560, INDIA.
Ph.: +91 - 9227110030
Fax: +91 - 2692 - 235209
E-mail: info@rotomotive.com
Website: www.rotomotive.com

Authorised Dealer